

GCU-11R (12/24V)

Prewired Relay Module

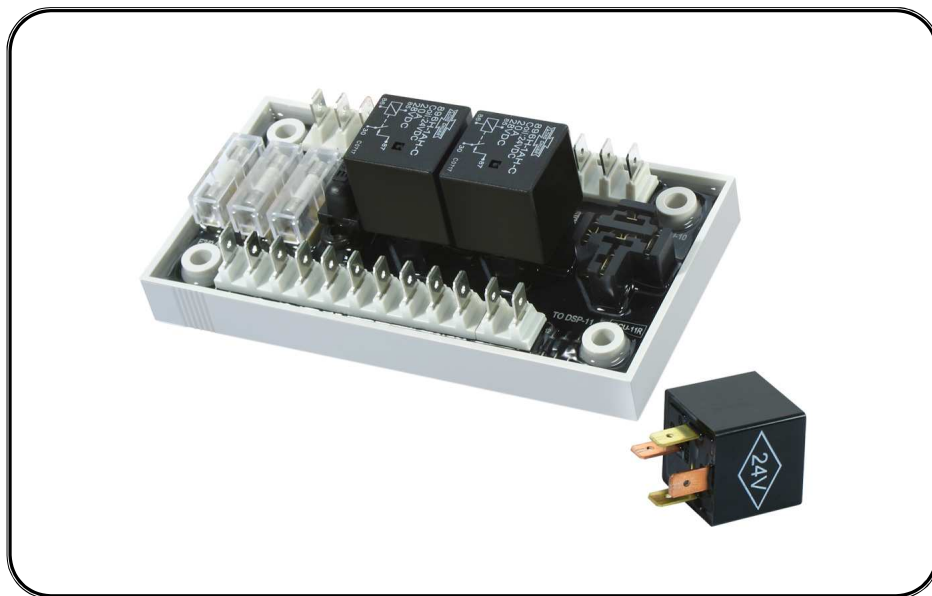

Optional Accessory to Save Time in Wiring the Control Panel



固也泰電子工業有限公司
KUTAI ELECTRONICS INDUSTRY CO., LTD.



Headquarters : No.3, Lane 201, Chien Fu ST., Chyan Jenn Dist., Kaohsiung, TAIWAN

Tel : + 886-7-8121771

Fax : + 886-7-8121775

URL : <http://www.kutai.com.tw>

GCU-11R PREWIRED RELAY MODULE

1. INTRODUCTION

GCU-11R Relay Module is designed to simplify wiring between the GCU-10 control module, DSP-10 display module and the genset. The Module is ready with male spade terminals; fuses and power relays. The power relays are used in the high current Preheat, Start, and Stop circuits.

GCU-11R saves time and money when wiring the control panel. The working voltage can be changed from 12VDC to 24VDC by changing the relays. The relay module is also compatible with other Engine Control Systems.

The Module is insulated with high anti-corrosion epoxy, suitable for use in the hostile environment inside the genset control panel.

2. GCU-11R OUTLINE DIMENSION

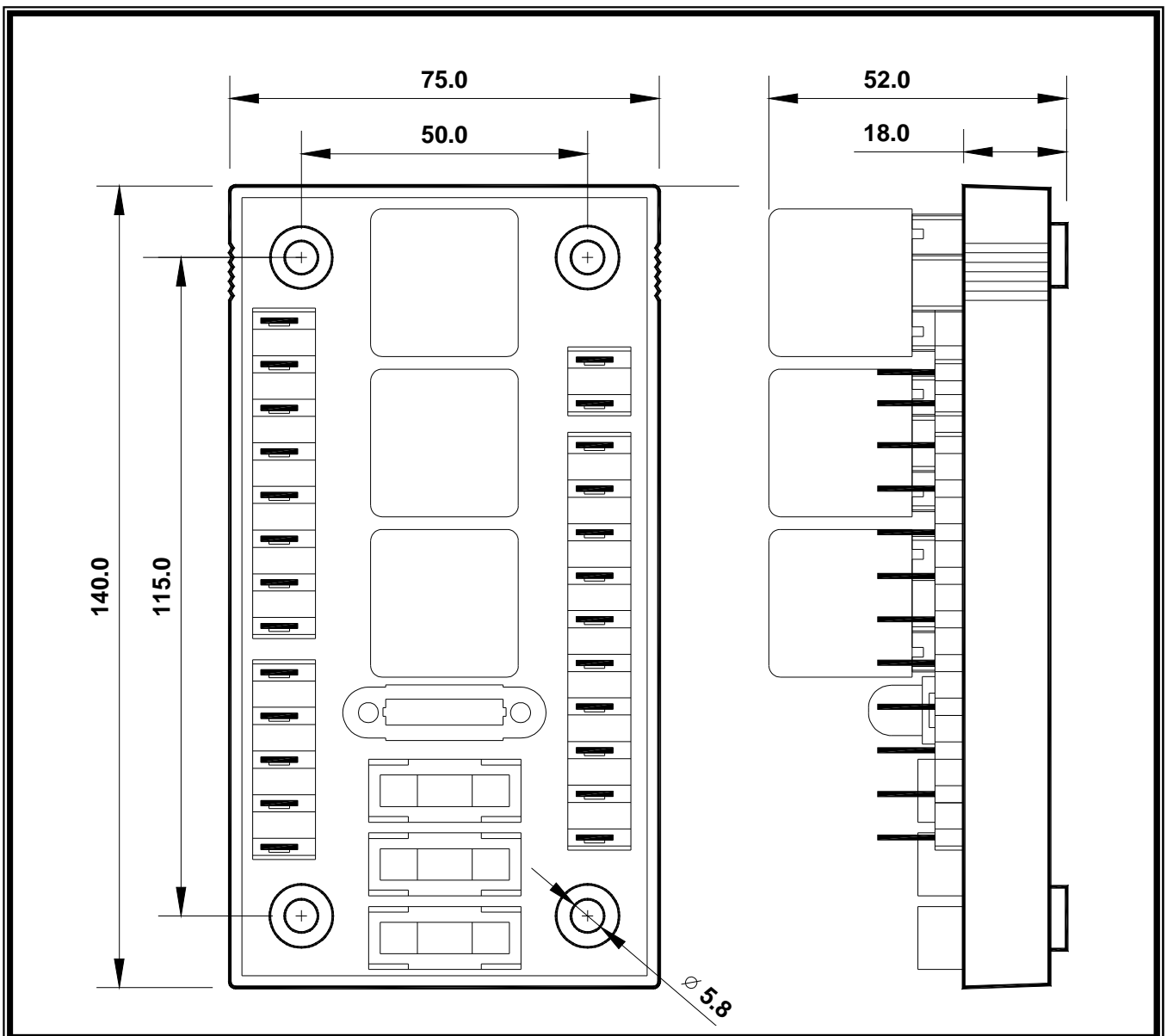

3. GCU-11R TERMINAL DESCRIPTION

3.1 EXTERNAL WIRING TERMINAL J3

PIN NO.	DESCRIPTION	NOTES
J3-1	AC Sensing Input (L3)	Connect to Alternator Phase L3 (10~500VAC Rated)
J3-2	AC Sensing Input (L2)	Connect to Alternator Phase L2 (10~500VAC Rated)
J3-3	AC Sensing Input (L1)	Connect to Alternator Phase L1 (10~500VAC Rated)
J3-4	AC Sensing Input (N)	Connect to Alternator Phase N
J3-5	DC Supply Input (+V)	Connect to Battery Positive (+V)
J3-6	DC Supply Input (-V)	Connect to Battery Negative (-V)
J3-7	Pre-heat Signal Output (+V)	Connect to Internal Heater (Rated Output 35 Amp)
J3-8	Start Signal Output (+V)	Connect to Starter Motor (Rated Output 35 Amp)
J3-9	Stop Signal Output (+V)	Connect to Fuel Solenoid or Valve Control (Rated Output 35 Amp)
J3-10	Accessory "ON" Output (+V)	Connect to Panel Meter
J3-11	DSP-11 Supply Output (+V)	Advance (+V) Terminal for DSP-11 Module
J3-12	DSP-11 Supply Output (-V)	Advance (-V) Terminal for DSP-11 Module

3.2 EXTERNAL WIRING TERMINAL J4

PIN NO.	DESCRIPTION	NOTES
J4-1	AC Sensing Output (L3)	Connect to DSP-10 Module AC Sensing Input (J1-6)
J4-2	AC Sensing Output (L2)	Connect to DSP-10 Module AC Sensing Input (J1-4)
J4-3	AC Sensing Output (L1)	Connect to DSP-10 Module AC Sensing Input (J1-2)
J4-4	DC Plant Supply Output (-V)	Connect to DSP-10 Module DC supply Negative Input (J2-9)
J4-5	DC Plant Supply Output (+V)	Connect to DSP-10 Module DC supply Positive Input (J2-8)
J4-6	AC Sensing Output (L1)	Connect to GCU-10 Controller AC Sensing Input (J1-1)
J4-7	AC Sensing Output (N)	Connect to GCU-10 Controller AC Sensing Input (J1-2)
J4-8	Accessory "ON" Signal Input	Connect to GCU-10 Controller Accessory "ON" Output (J1-5)
J4-9	Pre-heat Signal Input	Connect to GCU-10 Controller Pre-heat Signal Output (J1-4)
J4-10	Engine Start Signal Input	Connect to GCU-10 Controller Start Signal Output (J2-11)
J4-11	Engine Stop Signal Input	Connect to GCU-10 Controller Stop Signal Output (J2-10)
J4-12	DC Plant Supply Output (-V)	Connect to GCU-10 Controller DC supply Negative Input (J1-7)
J4-13	DC Plant Supply Output (+V)	Connect to GCU-10 Controller DC supply Positive Input (J1-6)

3.3 GCU-11R TERMINAL DIAGRAM

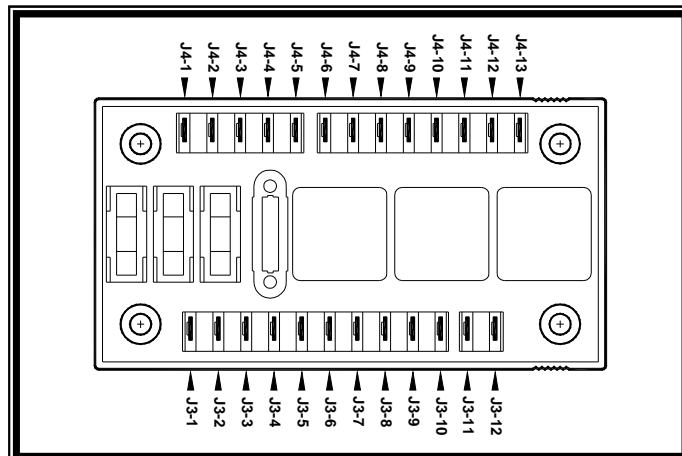

4. RECOMMENDED WIRING DIAGRAM

4.1 THREE PHASE RECOMMENDED WIRING DIAGRAM

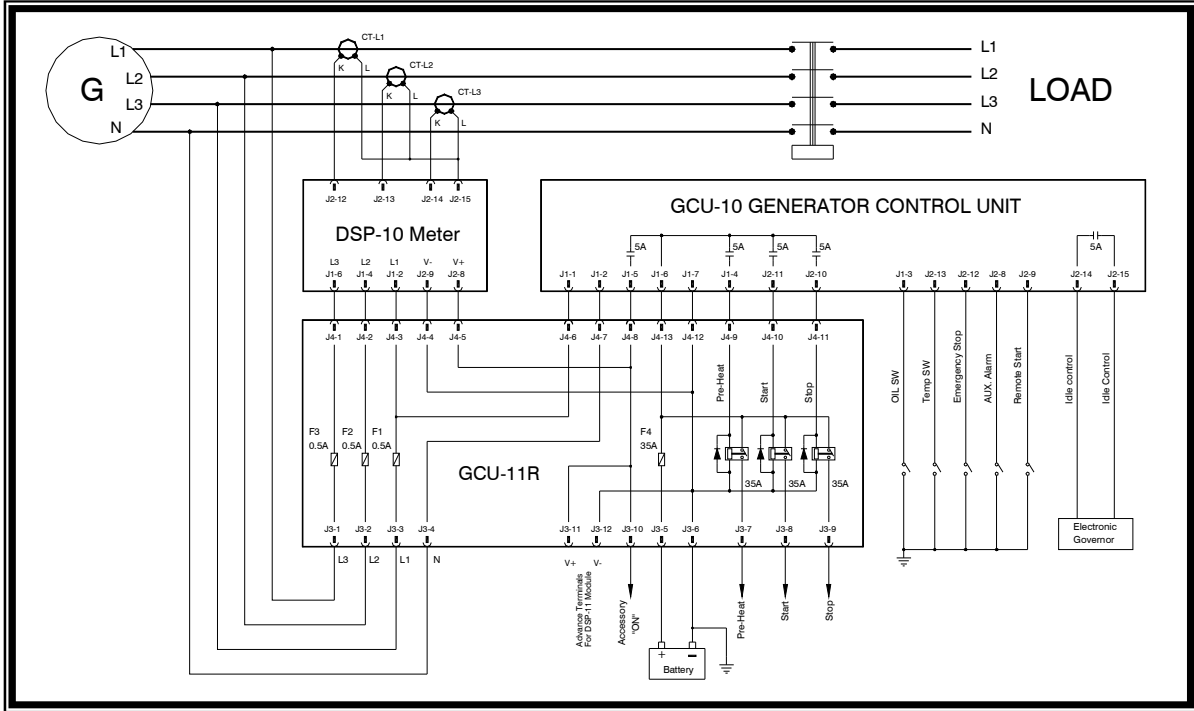

4.2 SINGLE PHASE RECOMMENDED WIRING DIAGRAM

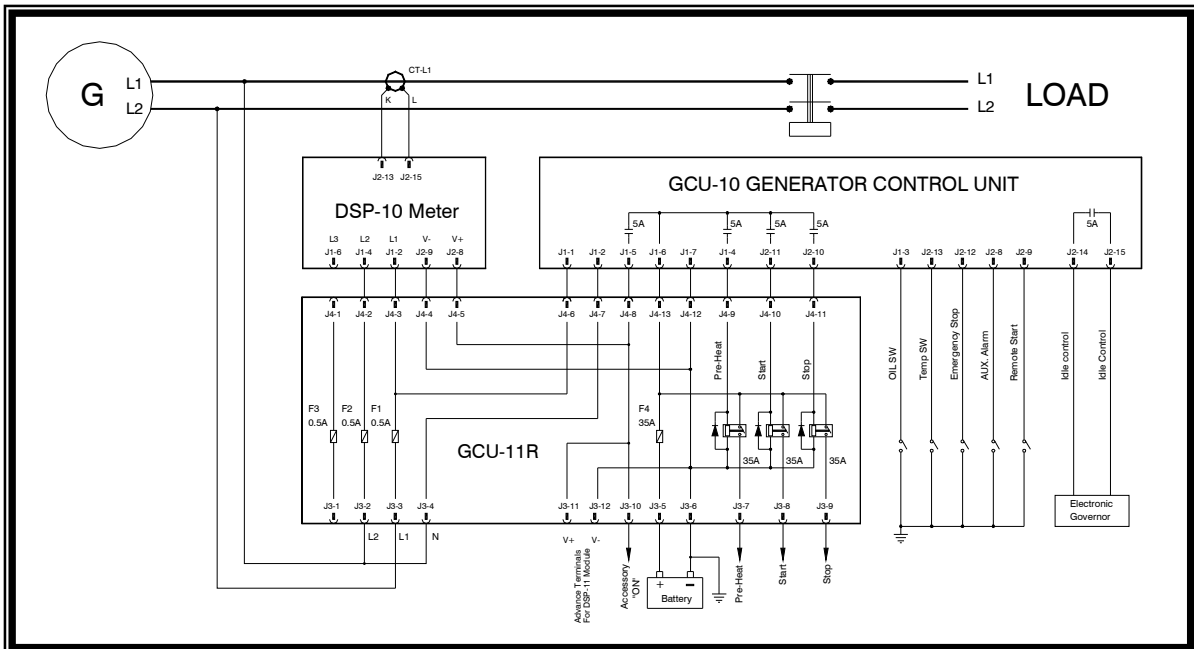

Please link to <http://www.kutai.com.tw> for detailed manual